

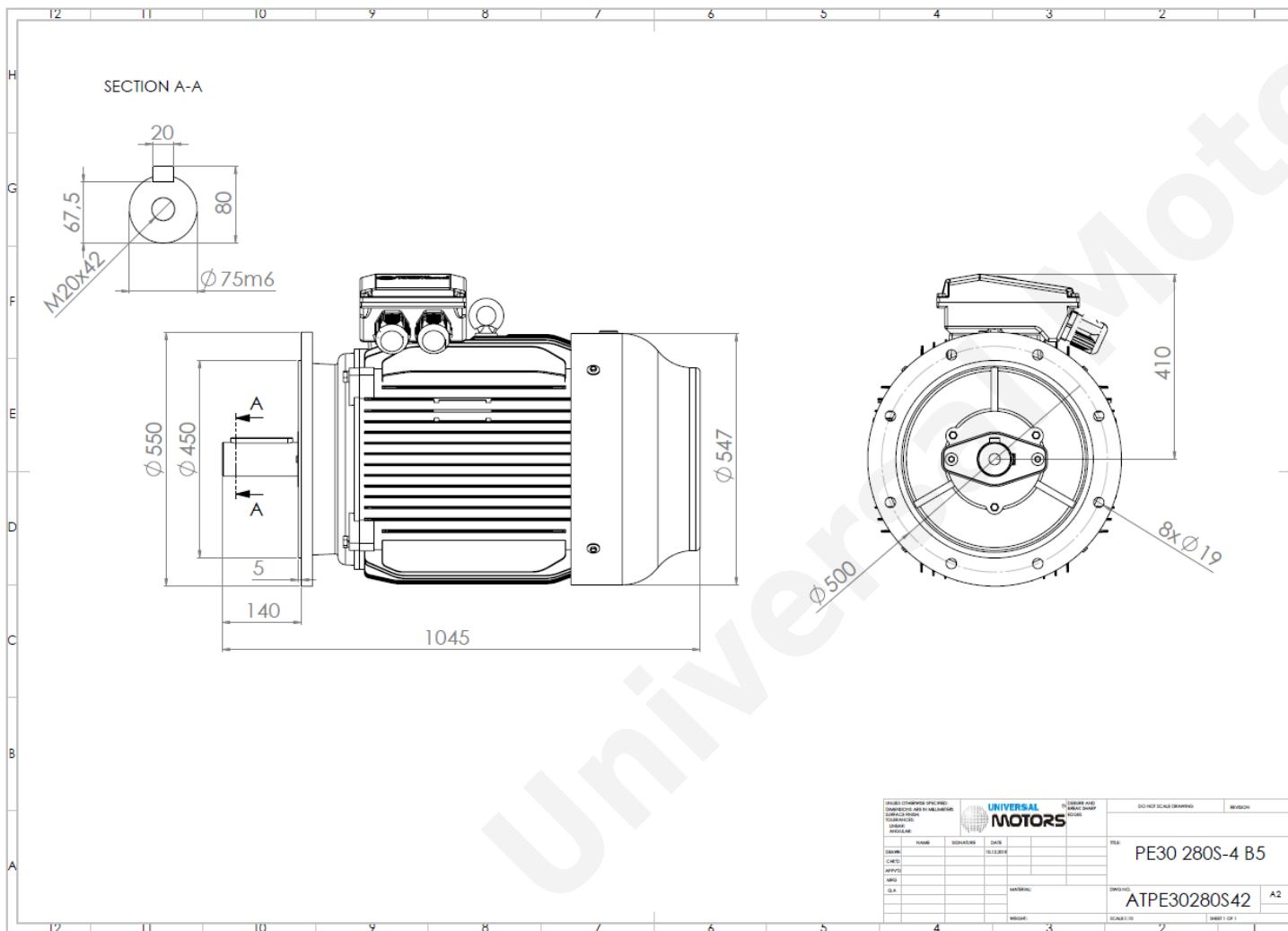

# TECHNICAL DATA

Three Phase Electric Motors - Cast Iron Frame  
 PE30 280S-8  
 37 kW / 50 Cv  
 740 RPM



Motor type:	<b>PE30 280S-8</b>
Output:	<b>37 kW / 50 Cv</b>
Speed ( $\text{min}^{-1}$ ):	<b>740 RPM</b>
Frequency:	<b>50 Hz</b>
Voltage:	<b>400 V</b>
Current:	<b>73.6 A</b>
Power factor ( $\text{Cos } \phi$ ):	<b>0.79</b>
Poles:	<b>8</b>
Insulation class:	<b>F</b>
Temperature rise Class:	<b>B</b>
Efficiency 50%:	<b>90.9 %</b>
Efficiency 75%:	<b>91.9 %</b>
Efficiency 100%:	<b>91.8 %</b>
Torque:	<b>477 N.m</b>
Tstarting/Tnominal:	<b>1.9</b>
Istarting/Inominal:	<b>6.6</b>
Tmaximum/Tnominal:	<b>2.0</b>
Noise:	<b>76 Db(A)</b>
Weight:	<b>561 Kg</b>
Bearing DE:	<b>6317 C3</b>
Bearing NDE:	<b>6317 C3</b>

**Regime - S1**

**Altitude - 1000m**

**Environment Temperature - 40°C**

## CONTACTS:

UNIVERSAL MOTORS Tel: +351 252 299 080  
 Rua de São Brás,745 Fax: +351 252 299 089  
 4480-782 VILA DO CONDE Mail: [geral@universalmotors.pt](mailto:geral@universalmotors.pt)

\* References applied only in the UK